

# BALL VALVES INTEC

K221, DN15 - DN100, PN16/40

floating ball, metal seated,  
single side spring loaded seat ring

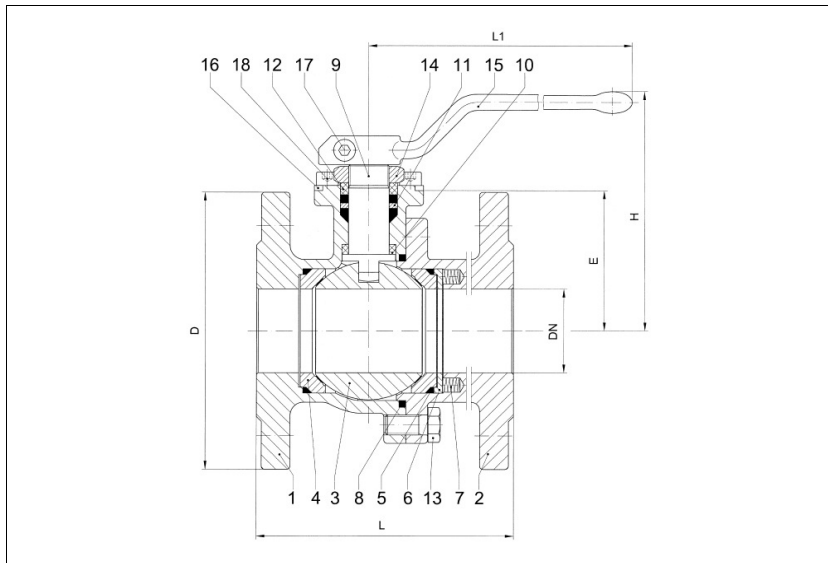

**Flanged ball valve**  
**full bore**  
**face to face acc. to EN 558, GR. 1**  
**face to face acc. to EN 558, GR. 27**  
**flanges acc. to EN 1092**

**Specification:**

Two-piece ball valve with flanges acc. to EN 1092, face to face dimensions acc. to EN 558, GR.1/GR.27, full bore, blow-out-proof stem, body material stainless steel (1.4408) or carbon steel (1.0619), anti-static device, free of non ferrous metals, seat 1.4571/1.4404 hard facing metal coated, stem packing cone ring construction acc. to temperature use, dynamic loaded adjustable, single side spring loaded seat ring, top flange DIN EN ISO 5211, approved by PED, certified acc. to GERMAN clean air act VDI 2440, Fire-Safe acc. to DIN EN ISO 10497, with lever.

Marking: INTEC K221

No.	Part	Material	Material				
<b>High temperature design</b>							
1	body	1.0619	1.4408				
2	cap	1.0619	1.4408				
3	ball	1.4408 hard facing metal coated					
4	seat	1.4571/1.4404 hard facing metal coated					
5	seat seal	Graphite					
6	follower ring	1.4571/1.4404					
7	spiral spring	Inconel X750					
8	body seal	Graphite					
9	stem	< 250°C	350°C	400°C	< 250°C	350°C	400°C
		1.4462	1.4313	1.4980	1.4462	1.4980	1.4980
10	below seal	E-carbon					
11	upper seal	1.4571/1.4404/Graphite					
12	bearing	E-carbon					
13	hex. screw	A4-70					
14	hex. nut self-locking	A2/1.4301					
15	lever	1.4408/1.4308/steel zincplated					
16	stopper	1.4301					
17	allen screw	A2-70					
18	allen screw	A2-70					
<b>Fire-Safe design</b>							
8	combined body seal	KF-Graphite					
10	below seal	KFGN/Graphite					
11	upper seal	KFAM/Graphite					
12	Fire-Safe seal	Graphite					
	ring	1.4571/1.4404					
	thrust washer	PEEK					
<b>Standard design</b>							
5	seat seal	KF					
8	body seal	KF					
10	below seal	KFGN/Graphite					
11	upper seal	KFAM/Graphite					
12	bearing	PEEK					

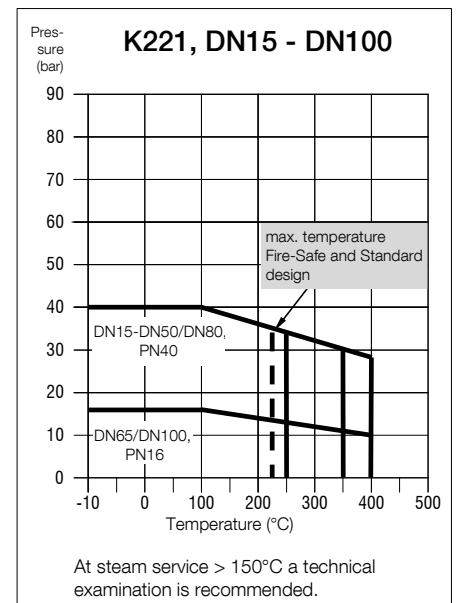

**Ordering example:**  
**INTEC K221, DN50, PN40, GR.27, 1.4408, high temperature, 1.4980 (stem)**

**Dimensions**

DN mm	PN	dimensions (mm)				D	E	top flange ISO	torque Nm*	weight kg	
		H	L1	L (GR. 1)	L (GR. 27)					(GR. 1)	(GR. 27)
15	40	95	160	130	115	95	39.5	F05	28	3.0	2.9
20	40	105	160	150	120	105	46.0	F05	36	4.0	3.7
25	40	114	180	160	125	115	49.5	F05	49	4.9	4.6
32	40	130	180	180	130	140	59.0	F05	71	6.7	6.4
40	40	135	300	200	140	150	76.0	F07	121	9.3	8.8
50	40	143	300	230	150	165	83.5	F07	180	13.0	12.1
65	16**	155	300	290	170	185	94.0	F07	179	16.0	15.0
80	40	197	500	310	180	200	102.5	F10	484	26.0	23.0
100	16**	215	500	350	190	220	120.5	F10	441	33.0	30.0

\* Necessary torque measured with treated water at Δ P acc. to pressure class and room temperature.

\*\* PN 40 flanges on request.